

**Guardian**  
Tactile Systems Pty Ltd

# tactiles

## Integrated Tactiles

**Guardian's Integrated Tactiles are a modular self-adhesive ground surface indicator system. They are specifically designed as a quick and easy installation for indoor and outdoor use.**

Integrated Tactiles meet all safety requirements and can be incorporated into new or existing areas to aid the vision impaired.

Our advanced polymer is very durable ensuring long service life; we offer a 10 year guarantee on our Integrated Tactiles.

- the Peel, Bond & Walk™ design can be installed and used immediately
- the self-adhesive cross linking polymer achieves permanent bond, even on undulating surfaces
- for external applications, our fast curing primer is applied to the substrate prior to installation
- integrated tactiles will not peel, lift, chip, crack or slip when correctly installed
- integrated tactiles fully comply with Australian Standards AS/NZS 1428

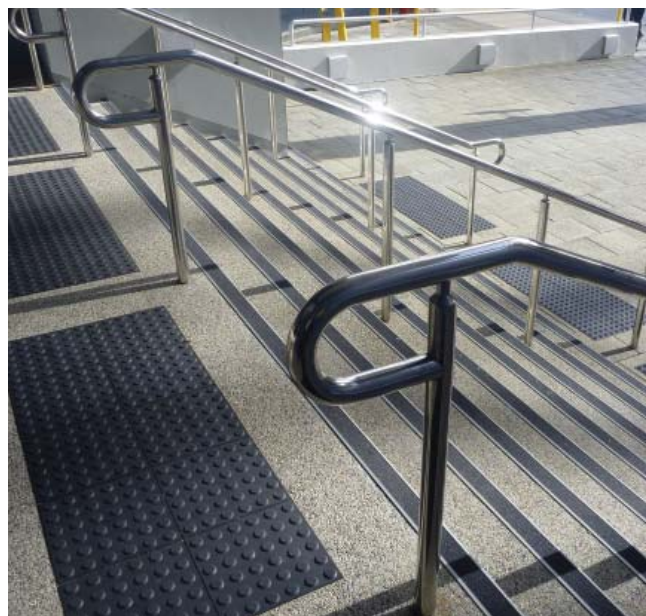

### Durable & UV Resistant

Integrated tactiles are exceptionally robust and stand up to Australia's harsh outdoor conditions. They are resistant to UV light and will not fade or discolour.

### Versatile

Integrated tactiles can be used both on new designs and retrofits to suit all applications. This includes:

car parks, bus stops, road crossings, kerbs, steps, entrance ways, intersections, stairways, escalators, fire escapes, ramps, railway platforms, walkways, passenger wharves, and much more

Guardian tactile indicators can be permanently installed onto any surface, including:

concrete, bitumen, timber, carpet, vinyl, rubber, plastic, tiles, marble, stone and brick paving



**10 year guarantee**  
*on Guardian Integrated Tactiles*



## Premium Quality

Guardian Tactiles are manufactured with premium quality polyurethane and are not affected by temperature extremes.

The Peel, Bond & Walk™ system is also designed for small areas, where alternative materials such as concrete, tiles and ceramic are difficult to install.

Integrated tactiles are available in a range of colours or can be custom made to suit your design requirements.

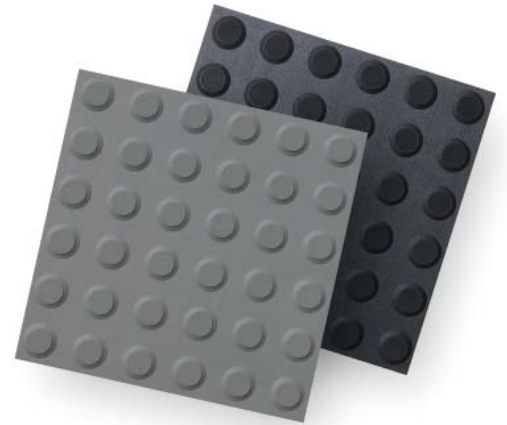

# Discrete Tactiles

**Guardian Discrete Tactiles are manufactured from the highest quality marine grade 316 stainless steel; they are suitable for both indoor/outdoor applications.**

The elegant design makes them ideal for prestigious locations. Discrete tactiles can be installed on various surfaces, including:

timber, tiles, marble, granite, terrazzo, concrete, carpet, vinyl and rubber

Discrete tactiles are designed to stay in place for many years. There are various installation options:

- shaft design (drill and secure with an adhesive or plug system)
- flat design (secure directly with an adhesive)

Discrete tactiles are guaranteed for 5 years from installation and comply with Australian Standards AS/NZS 1428.

## Drilling and Locating Templates

We supply drilling and locating templates to assist with the installation of discrete tactiles.

Our drilling templates will guide the drill holes to 50mm centres, and locating templates will accurately align the tactiles.



## Luminance Contrast for TGSi's

The choice of tactiles may depend on the colour of the substrate.

- integrated tactiles require a minimum luminance contrast of 30% with the amount of light reflected from the path of travel
- discrete tactiles require a minimum of 45% – 60% luminance contrast

**5 year guarantee**  
*on Guardian Discrete Tactiles*

# stair nosings

## Aluminium Nosings

**Guardian Aluminium Non-slip Stair Nosings comply with all Australian safety standards whilst presenting an aesthetic look for architectural design.**

Guardian aluminium stair nosings are protected with a 15 micron anodised coating. Stair treads are available in full 5.8 meter lengths or supplied pre-cut and pre-drilled to your requirements.

Guardian aluminium non-slip stair nosings are available in 3 different profiles:

- bullnose with a ramp back
- slimline with a ramp back
- slimline with a recessed back

We provide 2 types of stair nosing inserts: high quality polyurethane & premium silicon carbide.

Additional Features:

- extremely durable - full 5 year guarantee
- manufactured using high quality anodized aluminium
- waterproof and weatherproof against all kinds of conditions
- bonding system adheres to all surfaces and eliminates metal vibration
- hard wearing and cost effective solution
- supplied pre-cut and pre-drilled to your requirements
- easy to install, with a long lasting & impact resistant finish
- complies with Australian Standards AS/NZS 1428
- fully stocked and available in 5.8 meter lengths

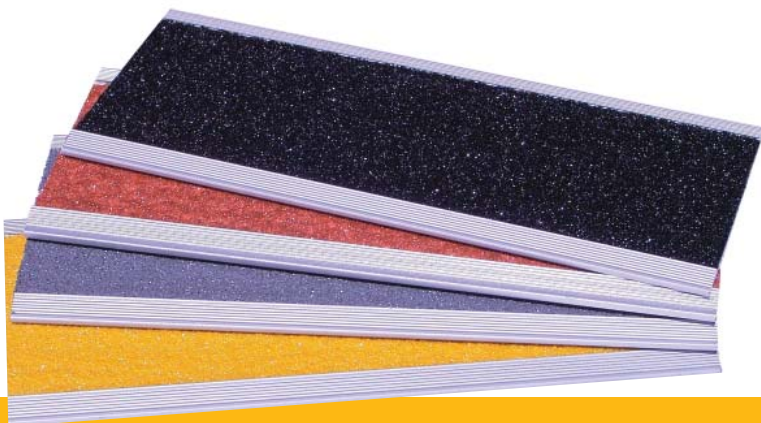
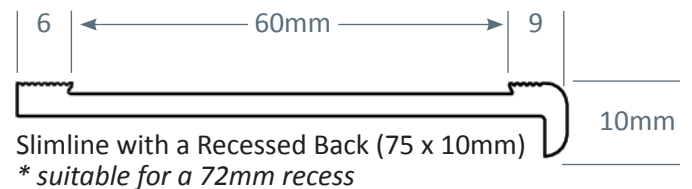
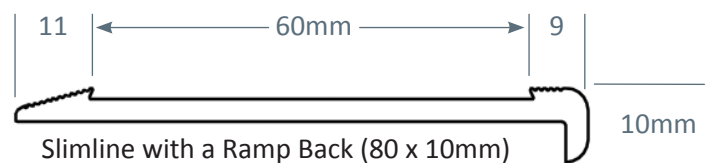
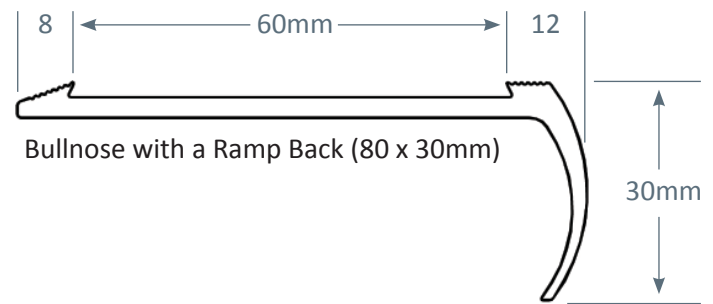

**5 year guarantee**  
on Guardian Aluminium Stair Nosing

# Fiberglass Nosings

**Guardian Fiberglass Stair Nosings are an ideal retrofit system for all types of stairs in the Industrial, Mining and Marine sectors. Fibreglass nosings provide a very safe platform with their aggressive grip surface.**

Guardian fiberglass stair nosings offer a fast, permanent anti-slip surface to the front edge to all types of stair surfaces, even in adverse conditions such as the presence of water and oil.

They are available in two colours: safety yellow and black.

Additional Features:

- extremely durable – full 5 year guarantee
- waterproof and weatherproof against all kinds of conditions
- anti-static and non-slip surface even when wet, oily, greasy or dusty
- excellent chemical, UV, corrosion, acid and alkaline resistant material
- bonding system adheres to all surfaces and eliminates metal vibration
- hard wearing with a tough grit for industrial application
- supplied pre-cut and pre-drilled to your requirements
- easy to install, with a long lasting & impact resistant finish
- will not discolour or fade over time
- fully stocked and available in 5.8 meter lengths

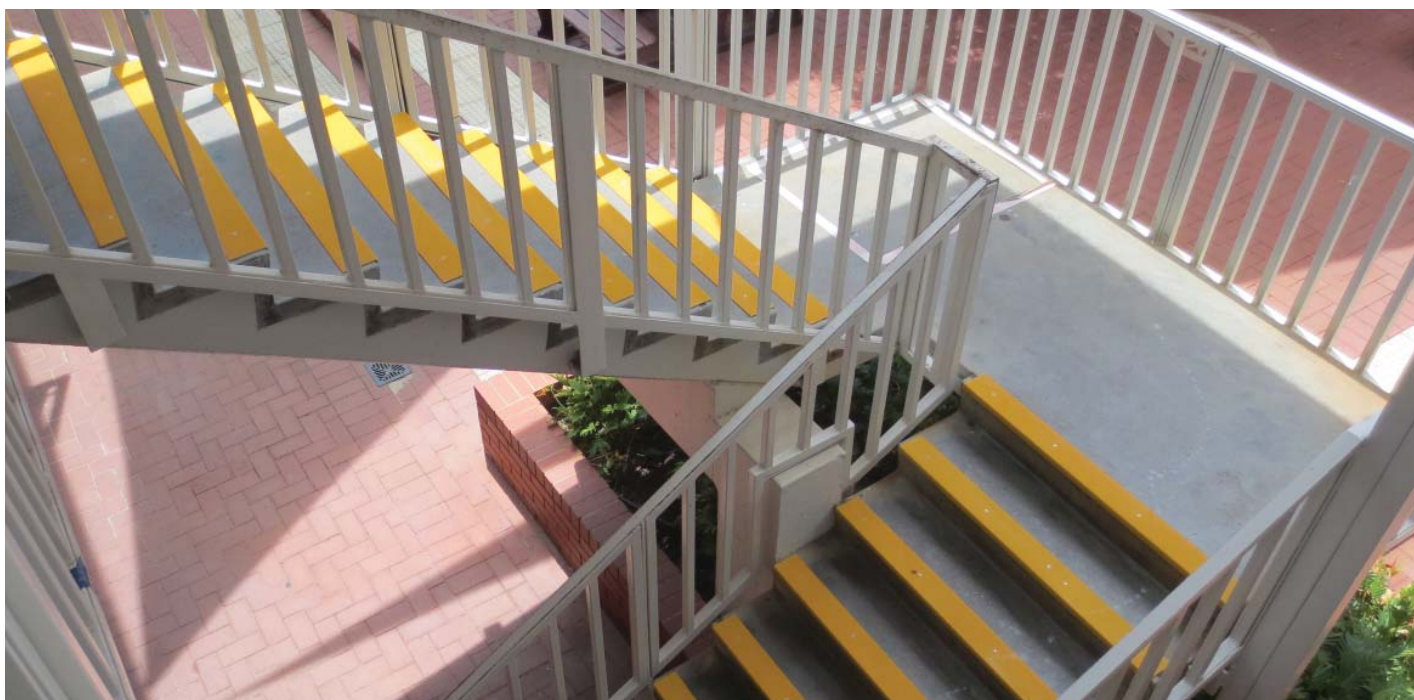
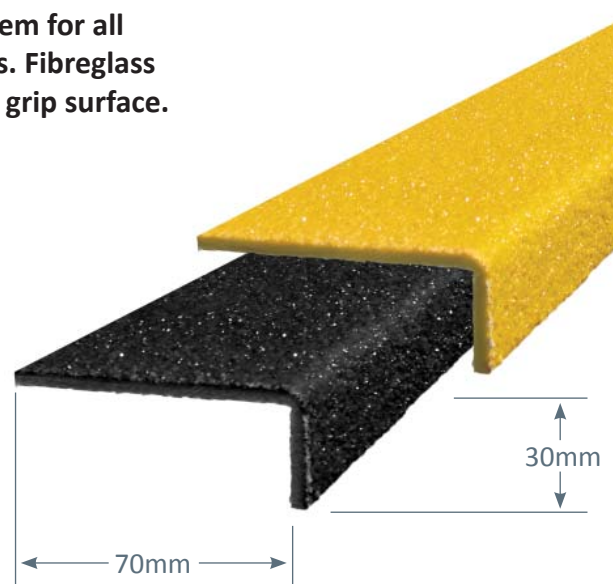



# Antislip Tape

**Guardian's heavy duty Antislip Tapes are designed for the prevention of slips, trips and falls. The fast and simple installation process makes them a versatile and economical solution.**

Guardian's safety tapes are by far the most durable on the market today. They are manufactured to the same standards and specifications as heavy duty industrial abrasive tapes making them outlast other non-slip tapes by up to 500%.

These premium non-slip safety tapes are designed for internal/external use and installed as a durable, slip resistant surface for a large variety of applications, such as:

trains, stairs, ramps, platforms, boats, forklifts, work vehicles and much more



**5 year guarantee**  
*on Guardian Antislip Tape*

# Wheel Stops

**Guardian Wheel Stops are the most economical way of providing a safe environment for public car-parks.**

Premium quality, heavy duty wheel stops are designed for maximum durability. They are moulded from a tough recycled rubber compound and finished with a highly visible yellow hazard pattern. Guardian fasteners are available for both concrete and bitumen surfaces.

Additional Features:

- more cost effective than traditional concrete wheel stops
- exceptionally light weight and economical to transport
- easily handled and installed by a single person
- complies with Australian Standards AS2890.1



**2 year guarantee**  
*on Guardian Wheel Stops*

# Braille Signage

**Guardian Braille Signs are moulded from a single piece of polycarbonate, creating a continuous surface with embossed tactile elements.**

Braille signs are suitable for internal/external use and comply with the Building Code of Australia (BCA). Customised signs can also be designed to your requirements.

Braille signs are encapsulated within a white or black backing plate and include a self-adhesive for convenient installation.



**10 year guarantee**  
*on Guardian Braille Signs*

# Professional Installation

**We have a large team of professional in-house installers who work around the clock to suit your requirements.**

They specialise in Guardian products and work to the highest standards of workmanship, in-line with the quality of Guardian's product range.

Guardian installations are provided with a warranty and comply with Australian Standards and the Disability Discrimination Act.

Guardian Tactile Systems are renowned for their after sales service; both in the installation of products, and the ongoing follow-up to ensure complete customer satisfaction. We also offer a full range of quotation services and on-site measurements.

Schedule an appointment with our friendly customer service team to ensure that all safety products are professionally installed by the experts.





**Guardian**  
Tactile Systems Pty Ltd

T +61 8 9240 1888

F +61 8 9240 1988

E [sales@guardiantactile.com](mailto:sales@guardiantactile.com)

[www.guardiantactile.com](http://www.guardiantactile.com)